

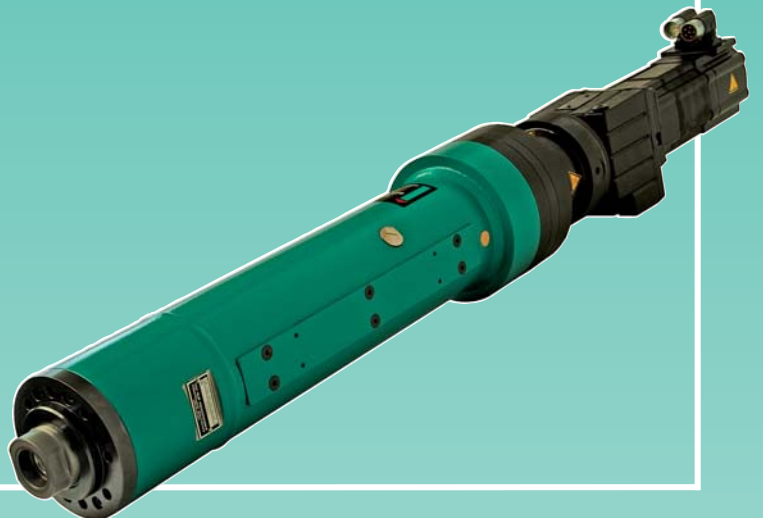

TOX®-ElectricDrive line-Q²

! The TOX®-Servo-Powerpackage !

- Electro-mechanical Servo-Systems
up to 100 kN Press force



When work processes require high flexibility and precision, then conventional drives are often no longer sufficient. This calls for the use of electromechanical servo drives.

Tailored drives up to 100 kN.

Advantages TOX®-ElectricDrive line-Q²:

- The system is pre-configured and thus, ready for service
→ plug and play
- The basic version allows easy installation, parameter based programming and operation, i.e. without specialized programming knowledge
- Maximum energy efficiency through the use of DC synchronous permanent magnet motors, i.e. significantly reduced operating costs compared to conventional drives
- High life expectancy and robustness due to the ball screw spindle
- Motor with integrated holding brake
- High-dynamic performance
- Upgradable up to and including safety category 4 as per EN ISO 13849, Performance level e as per EN ISO 13849-1 and SIL3 as per EN/IEC 62061 on request
- Future-oriented project planning and very good retooling capability due to its universal applicability
- Stand-alone operation without PC/PLC is possible

Applications for TOX®-ElectricDrive line-Q²:

Assembling, Press-fitting, Mounting	Inserting, Fastener-Insertion, Insertion (of function elements)	Riveting, Crimping, Flaring	Punching, Piercing	Coining, Marking, Stamping	Clamping, Tensioning, Peening	Pressing, Compressing

Scope of delivery basic version:

The set:

TOX®-Servo spindle EPQS	Axis-Controller line-Q ²	Cable set consisting of motor cable and resolver cable	Terminal310	Ballast resistor

Mechanical
Housing with ball screw spindle, working rod, bearing, resolver, motor with reducer and holding brake

Controller
Complete control unit, incl. ballast resistor, Terminal310 plus CAN cable.

Cable set
Applicable for use with cable tracks (pay attention to the minimum bending radius).
1x motor cable, 1x resolver cable (standard length 5 m, additional lengths up to 25 m in steps of 5 m are available). Cables for robotic applications also available on request.

Accessories EPQS

- Grease Gun and Special Grease
- Calibration Case (only for full version)

Refer to catalog TOX®-ElectricDrive

The electromechanical servo spindle

For CAD files, please visit us at www.tox-en.com

Design EPQS

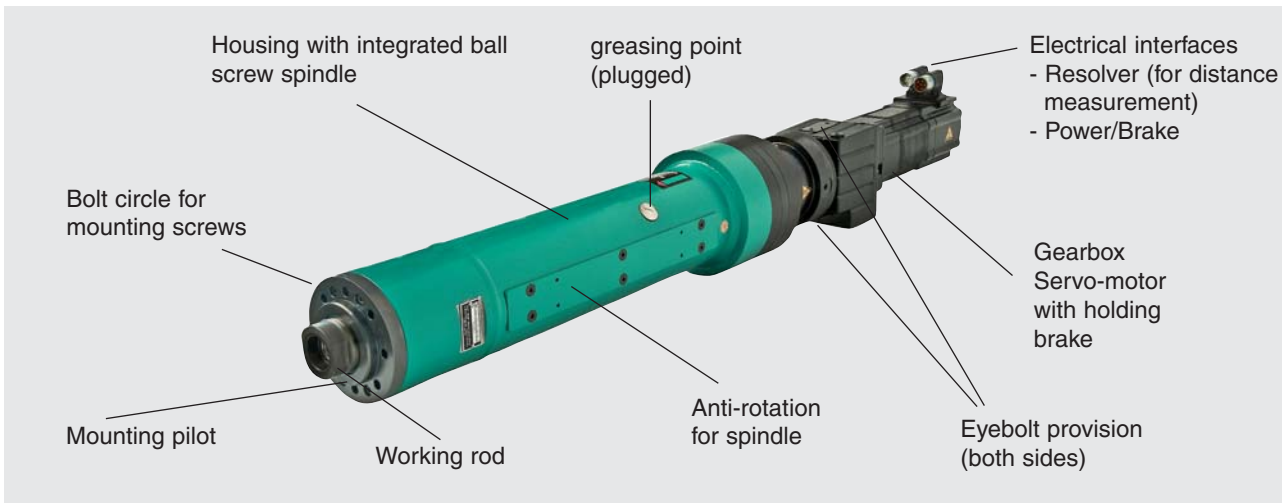

Mounting instructions:

The working rod should be guided externally in order to avoid any potential side loads. You will find corresponding examples in the TOX®-Presses catalog. The connection to the external guidance or ram guide plate must be done using a flexible coupling. For more information on our couplings, please see data sheet 10.00 for TOX®-Powerpackage accessories.

Referencing:

Generally, referencing is done using the internal positive stop of the servo drive.

Grease Access:

Accessibility to the grease access point has to be allowed and designed in (page 4).

Mounting Orientation:

Vertical working rod to extend downward. Please contact us in advance for other mounting orientations.

Holding Brake:

The holding brake is internally actuated by the controller. The brake is lifted before the initiation of the process and automatically closed after completion.

Connection of Components (Basic Version)

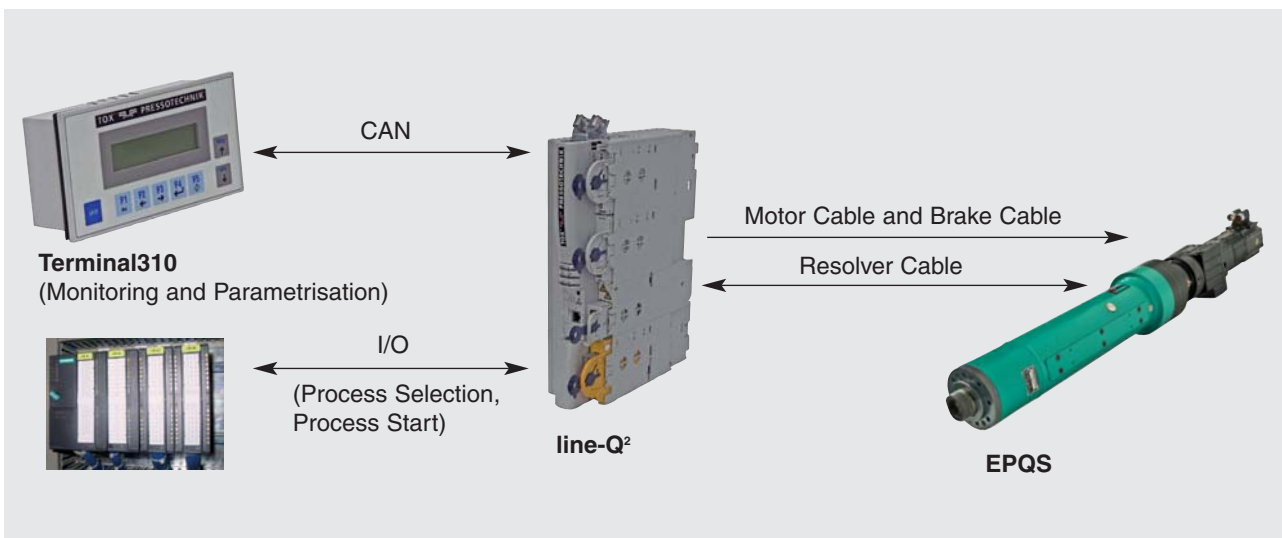

Data sheet

TOX®-Electric Power Module EPQS 25, 55, 100 kN

For CAD files, please visit us at www.tox-en.com

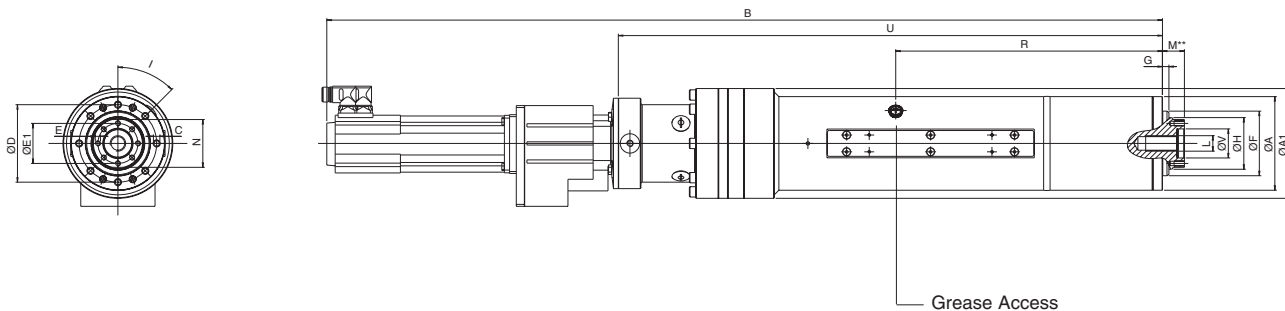

Dimensions

Order no.	Stroke	Nominal force [kN]	A	A1	B	C	D	E	E1	F ₁₇	G	H	I	L	M	N	R	U	V _{H7}	Weight approx. kg
EPQS 025.000.	200	25	115	150	1078	8xM8x30	90	-	-	75	10	50	45°	M20	30	SW 41	352	686	30	72
EPQS 055.000.	200	55	145	170	1294	8xM10x35	120	8xM8x16	62	100	10	80	45°	M24	34	SW 74	413	843	45	106
EPQS 100.000.	200	100	190	210	1407	8xM12x40	160	8xM10x20	70	140	20	100	45°	M30	50	SW 85	417	923	55	218

Specifications	EPQS 025.000.200	EPQS 055.000.200	EPQS 100.000.200
Mechanical			
Rated force* push	25 kN	55 kN	100 kN
Rated force pull	25 kN	55 kN	100 kN
Max. stroke	200 mm	200 mm	200 mm
Max. speed	100 mm/s	100 mm/s	100 mm/s
Max. short-term overload	10%		
Positional repeatability under load***	< ± 0,01 mm		
Sensors			
Resolver	x	x	x
Resolution	0,0003 mm	0,0003 mm	0,0003 mm
Electrical			
Protection class	Motor/drive IP54 (as component)		
Mains supply	see axis controller		
Climatic conditions			
	+ 10 bis + 40°C, from 40° C performance loss, max. 55° C; air moisture < 75%, without condensation		

*Recommended operating range 5 – 100% (full version with force sensor)

**Zero position of drive is the reference (marked) position + 3 mm

***in thermal transient condition

Accessories:

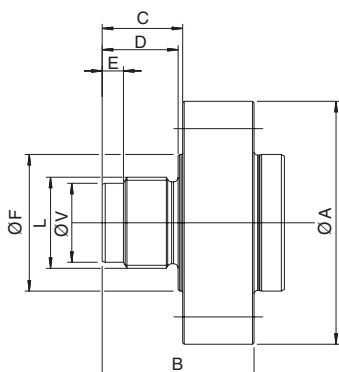

HZZ-Adapter for the working rod
For mounting of tool holder ZWK or force sensor ZPS.
Technical data available on request.

Order no.	Type	Fits	Max. press force (kN)		A	B	C	D	E	F	L	V ₉₆
			push	pull								
HZZ 022.020.000	EPQS 025		25	20	50	42	26,5	25	7	30	M22x2	18
HZZ 030.01.000	EPQS 055		55	40	80	50	26,5	25	7	45	M30x2	26
HZZ 030.00.000	EPQS 100		100	40	98	55	26,5	25	7	48	M30x2	26

TOX[®]-Axis-Controller line-Q²

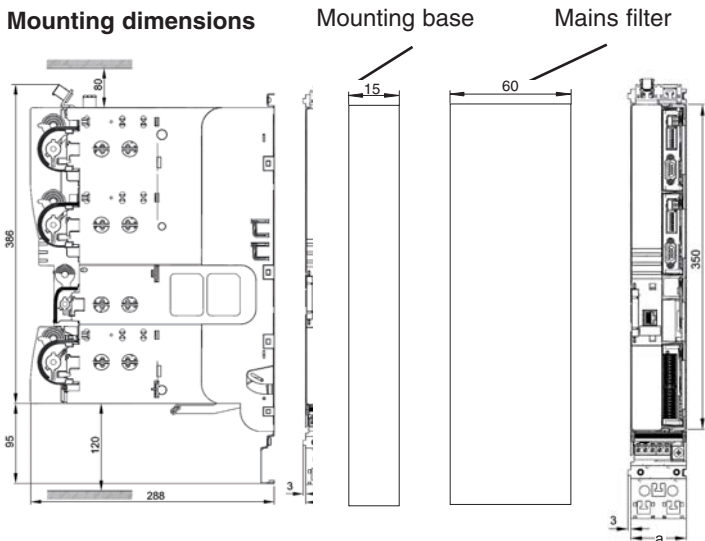

Size of the TOX [®] -Electric Power Module	Dimensions a (mm)	Weight (kg)
EPQS 025 EPQS 055	90	5,3
EPQS 100	120	8,1

- Standard industrial power input
3 x 180 - 550 V (+0% ; -0),
Nominal Power from 400 V AC 50/60 Hz
- Dimensions of ballast resistor:
W/H/D 30/60/355 mm
- Built-in depth of control cabinet 400 mm

General data and installation requirements

Operating conditions			
Circuit Type	With grounded star circuit	Unlimited use	
	IT-Net	Follow instructions for special measures!	
Standards			
Conformity	CE	Low Voltage Guide line (73/23/EWG)	
Approvals	UL 508C	Power Conversion Equipment (File-No. 32659)	
Enclosure			
Enclosure type	EN 60529	IP20	Not in the motor terminal box area
	NEMA 250	Contact Protection type 1	
Climatic Conditions			
Operation*	IEC/EN 60721-3-3 EN 50178	3K3 (-10 ... +55°C) Derating of rated output current +45 ... +55°C: 2,5%/°C	
Humidity			max. 85%, without condensation

*In case of an installation at 1000 m above sea level the reduction of the nominal current will be 15%/1000 m.

Block diagram

Use of the TOX[®]-ElectricDrive-System.
Simplified diagram.

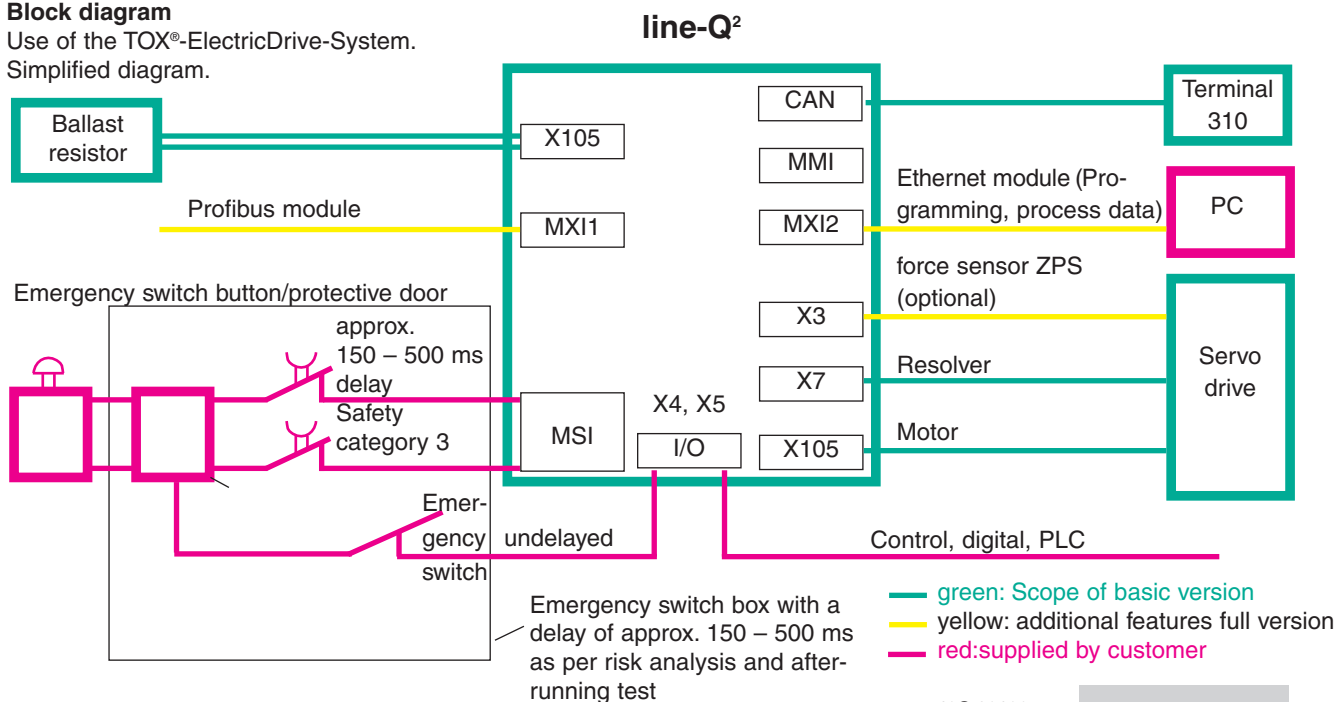

The matching TOX[®]-Axis-Controller of line-Q²

Configurations

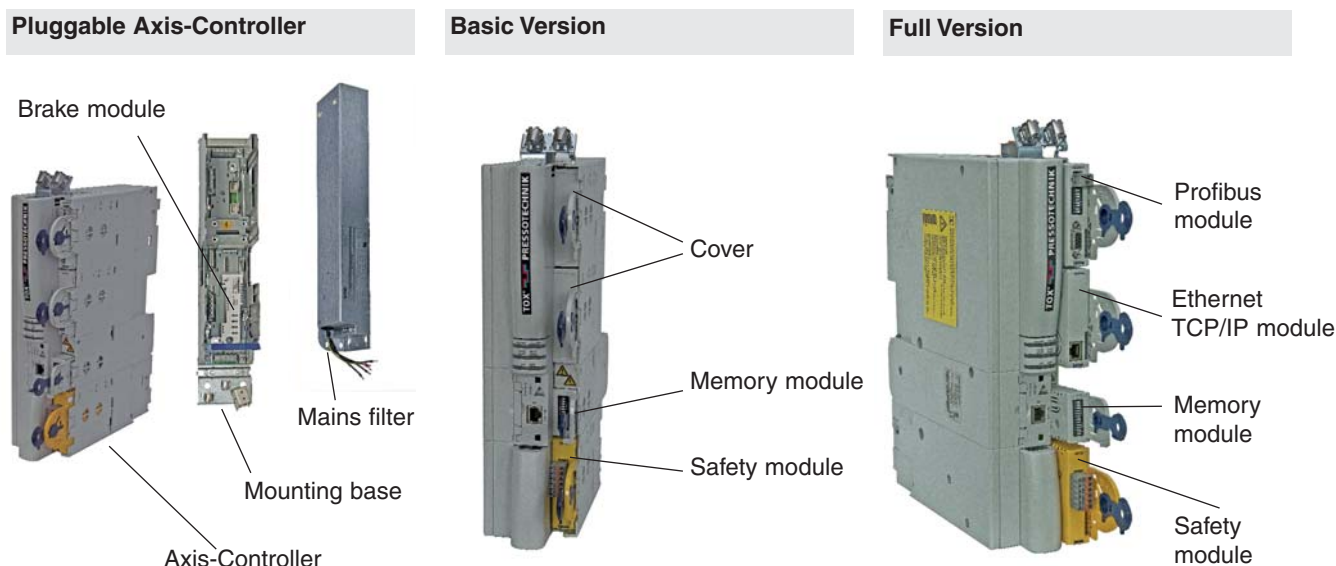

By simply plugging the axis-controller in or out off the mounting base, it can be quickly connected or replaced. Due to the plugging system the modules are easy to change.

Overview of available configurations:

The modular built line-Q² Axis-Controller is available in 2 differently configured versions:

Basic Version

This controller version is a basic servo positioning axis with force limitation through current monitoring.

Process selection over I/O (Fieldbus optional).

Programming of the controller only with Terminal310.

The functionality is standardized and not customizable.

Full Version

This version should be considered for more advanced joining applications, the additional features are:

- Control over Fieldbus
- Parametrisation, Visualizing and Data export utilizing TOX[®]softWare line-Q²
- Force Monitoring over external rod end load cell Type ZPS

Building Blocks	Configurations		Description
	Basic Version	Full Version	
Axis-Controller	x	x	Base
Mains filter	x	x	Mains filter (panel mount)
Mounting base	x	x	The mounting base will be installed on top of the mains filter. The base unit will be snapped into the mounting base
Terminal310	x		Operator Panel to edit parameters of press movements, display of Final Values and Error codes
Ethernet module TCP/IP		x	PC interface for parametrisation/visualization with TOX [®] softWare line-Q ²
Profibus module	*	x	Interface control bus (other bus systems avail).
Memory module	x	x	Data Storage Module for Applications
Safety module	x	x	Safety module
Force sensor type ZPS		x	incl. cable and HZZ-Adapter for rod end mounting See TOX [®] -Powerpackage data sheet 10.00
Holding brake (integrated in motor)	x	x	Controlled over included pluggable brake module
Motor cable incl. brake cable	x	x	Applicable to use with cable tracks, Minimum cable length 5 m, additional lengths up to 25 m steps of 5 m are available
Resolver cable	x	x	
TOX [®] softWare line-Q ²		x	Similar functionality like TOX [®] softWare line-X (as described in TOX [®] -ElectricDrive catalog line-X), but without technology functions
Number of Programs	8 max of 5 functions	240 with 2200 functions	
Program selection	over I/O*	over Bus, I/O or TOX [®] softWare line-Q ²	

* Optional over Fieldbus, on request

Process Structure, Parameterising and Visualizing

Basic Version

Process Structure

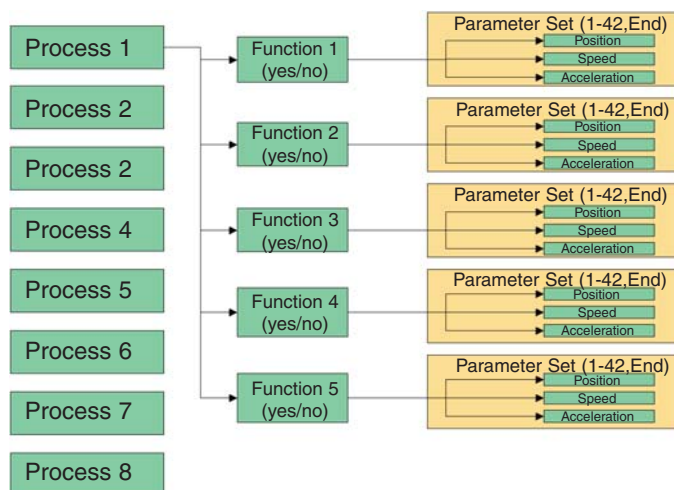

8 Processes can be freely programmed.
 The Processes “Referencing, Jog Forward, Jog Reverse” are already factory configured.
 Each program allows 5 functions (move functions). Within each function there are 3 allowed editable functions:

- Position
- Speed
- Acceleration

The maximum press force can be set for each process.
The press force is monitored only via the motor current.

Parameterising and Visualizing with Terminal310

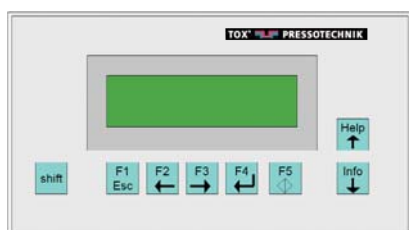

The Terminal310 is connected to the controller through a CANBus interface. Screen navigation through function keys.

Mounting Dimensions:
 Cut out Measurements: 157 x 77 mm.
 Minimum depth 41 mm (without connector)

Monitoring



After initial power up or restart, the terminal automatically displays the monitoring screen. This screen displays the current force, position and the last final values.

Process Editor

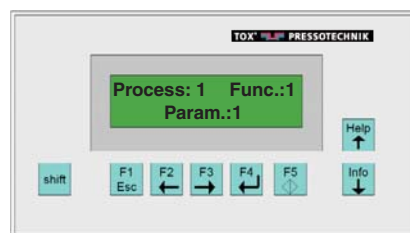

Selection of process, function and parameter number. The max press force for the respective process is adjusted in this screen.

Parameter Selection

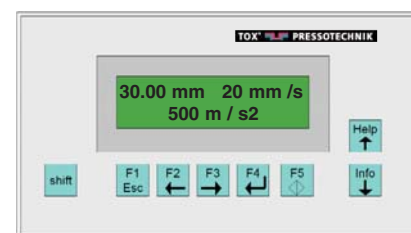

In this screen, the parameters are set and position windows can be programmed. The last 10 final values can be displayed. Diagnostic messages will be displayed with Error Number and Error Text.

Full Version

In this version, parameterising, visualizing and data export is done by TOX[®]softWare line-Q², utilizing a PC. The functionality of TOX[®]softWare line-Q² is similar to TOX[®]softWare line-X (please refer to catalog TOX[®]-ElectricDrive).



Product Range

TOX®-Powerpackage



TOX®-PowerKurver



TOX®-ElectricDrive



TOX®-FinePress



TOX®-Presses



TOX®-Controls,
TOX®-Monitoring



TOX®-Joining-
Systems



TOX®-Tongs



TOX®-Punching
TOX®-Coining



TOX®-Press-Fitting



TOX®-Production
Systems



TOX® PRESSOTECHNIK GMBH & CO. KG
 Riedstrasse 4
 D-88250 Weingarten
 Tel. +49 (0) 7 51 / 50 07-0
 Fax +49 (0) 7 51 / 5 23 91
 E-Mail: info@tox-de.com
www.tox-en.com